



MODEL H8238 110/220V ON/OFF SWITCH INSTRUCTIONS

For questions or help with this product contact Tech Support at (570) 546-9663 or techsupport@grizzly.com

!WARNING

To reduce risk of serious burns, electrocution or death when installing this switch:

- Only use this switch to replace an existing machine switch that has the same physical configuration and equivalent electrical specifications/ratings.
- Installation must only be performed by an electrician or qualified service personnel, and all applicable electrical codes must be adhered to.
- Turn off and completely disconnect all power sources to the machine before installing the switch.
- Do not use this switch in wet or damp locations, or near explosive fumes or flammable liquids. It is not sealed or rated for these environments.
- Make sure there is a verified machine ground on the circuit this switch is installed.

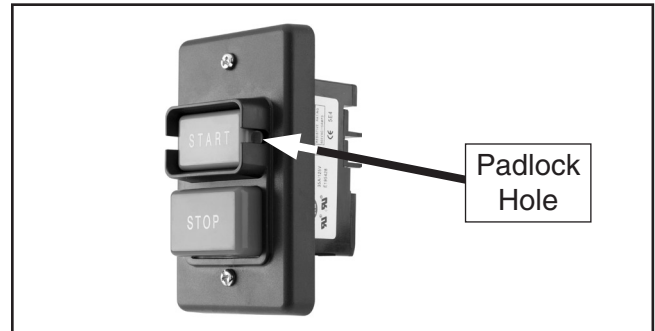

Figure 1. H8238 ON/OFF Switch.

Introduction

The Model H8238 features a recessed START button that can be disabled with a padlock. The switch assembly can be mounted on a standard electrical box.

Specifications

Rated Voltage.....	120/240V
Rated Horsepower/Current at 120V.....	2HP/35A
Rated Horsepower/Current at 240V.....	3HP/20A
Phase.....	Single
Padlock Shaft Size.....	$\frac{3}{16}$ "

COPYRIGHT © APRIL, 2011 BY GRIZZLY INDUSTRIAL, INC.
WARNING: NO PORTION OF THIS INSTRUCTION SHEET MAY BE REPRODUCED IN ANY SHAPE
OR FORM WITHOUT THE WRITTEN APPROVAL OF GRIZZLY INDUSTRIAL, INC.

#TS13932 PRINTED IN CHINA

Installation

When installing the H8238 switch, use the wiring diagram in **Figure 2** to ensure proper wire connections.

! WARNING

This switch is intended to be connected to stranded wire with insulated crimp-type ring wire terminals.



All crimps must be "pull-checked" to ensure that wires are securely crimped and will not fall out with moderate tension or when exposed to normal machine vibration.

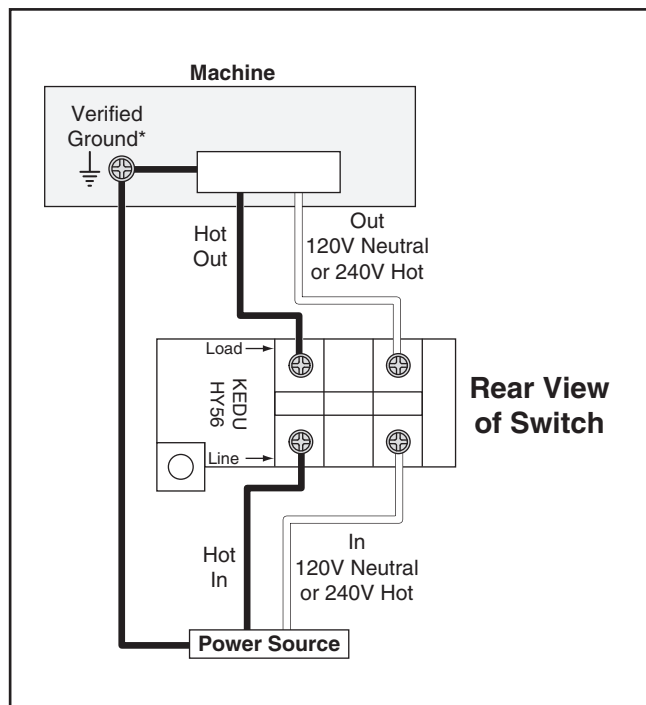

Figure 2. H8238 wiring diagram.

*The machine **MUST** be connected to a verified ground. In the event of certain malfunctions or breakdowns, grounding reduces the risk of electric shock by providing a path of least resistance for electric current.

Disabling & Locking Switch

The ON/OFF switch can be disabled and locked by inserting a padlock through the ON button, as shown. Locking the switch in this manner can prevent unauthorized operation of the machine, which is especially important if the machine is not stored inside an access-restricted building.

IMPORTANT: Locking the switch with a padlock only restricts its function. It is not a substitute for disconnecting power from the machine when adjusting or servicing.

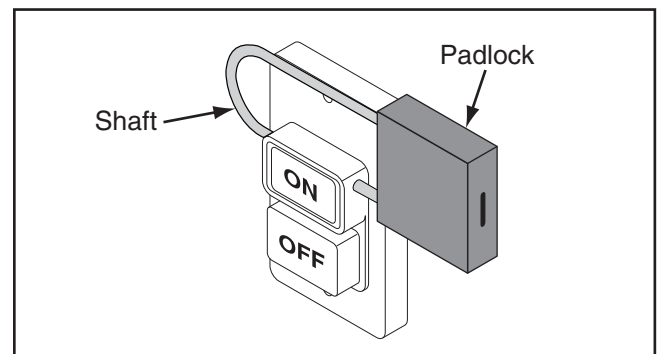

Figure 3. Switch disabled by a padlock.

! WARNING

Children or untrained people can be killed or seriously injured by this machine. This risk increases with unsupervised operation. To help prevent unsupervised operation, disable and lock the switch before leaving machine unattended! Place key in a well-hidden or secure location.

NOTICE

The padlock shaft diameter is important to the disabling function of the switch. With any padlock used to lock the switch, test the switch after installation to ensure that it is properly disabled.

Figure 4. Minimum lock shaft requirements.

